



# Sustav tehničke zaštite Grada Šibenika

Danijel Mileta, zamjenik gradonačelnika Grada Šibenika

# Ciljevi projekta

- Uvođenje reda u promet u mirovanju
- Podizanje sigurnosti prometa u kretanju, posebice sigurnosti djece u prometu
- Podizanje opće sigurnost grada i prevencija kriminaliteta
- Zaštita imovine Grada i građana
- Osiguravanje kontinuiteta visoke razine sigurnosti grada Šibenika, kao jedne od najsigurnijih turističkih destinacija u Hrvatskoj

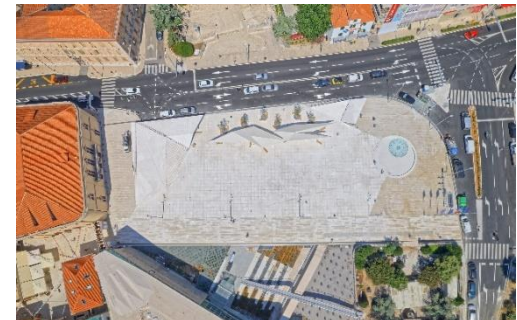

# Opseg projekta

- Opseg izvođenja: **88 mikrolokacija, 323 mrežne analitičke kamere** (42 inteligentne PTZ kamere za detekciju nepropisnog parkiranja, 67 prometno analitičkih kamera, 214 kamera visoke rezolucije za opći video nadzor)
- Izvedba optičke okosnice i komunikacijske infrastrukture
- Prometna analitika
- Prometno redarstvo (automatska detekcija nepropisnog parkiranja)
- Sustav video nadzora javnih površina
- Implementacija 2 nadzorna centra



# Izvedba optičke okosnice i komunikacijske infrastrukture

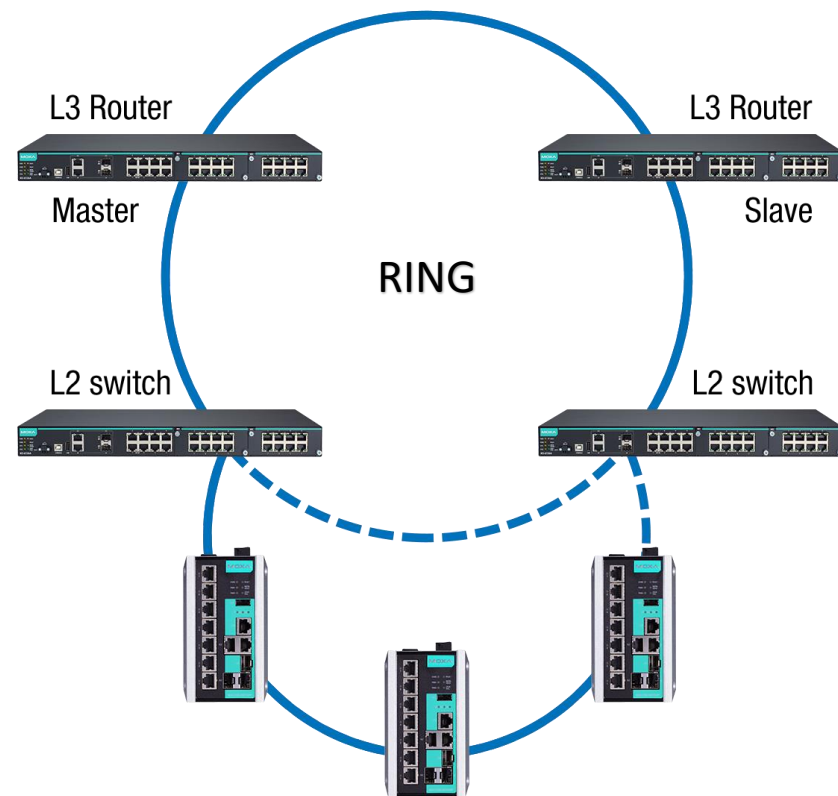

# Prometna analitika

- Nadzor prometnog toka na bitnim prometnicama Grada

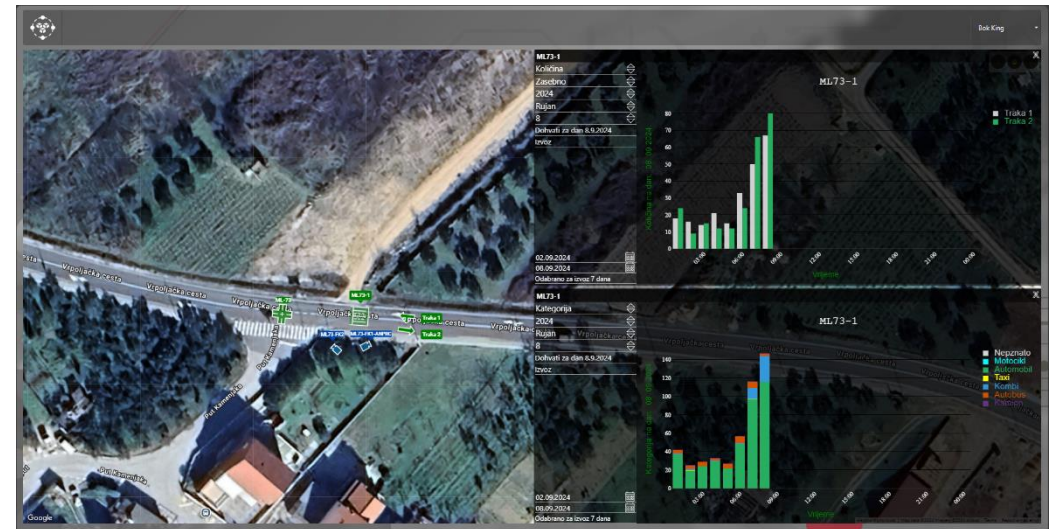
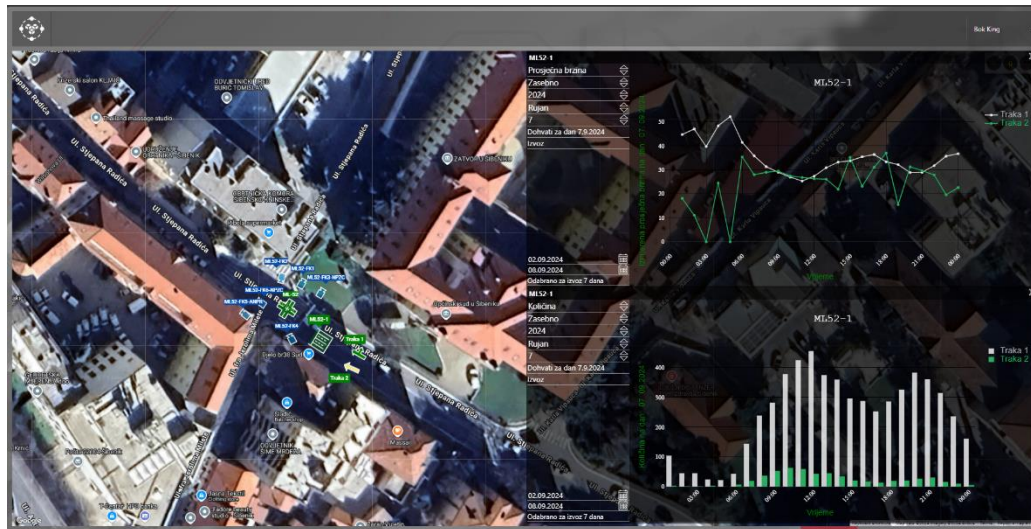
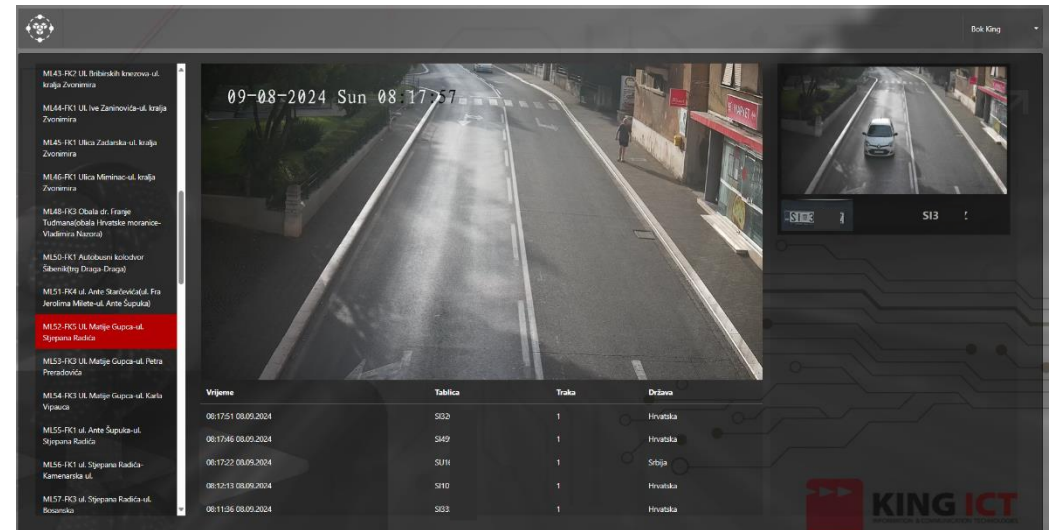

# Prometno redarstvo, uvođenje reda u promet u mirovanju

- Potpuno automatizirani sustav prepoznavanja nepropisno parkiranih vozila

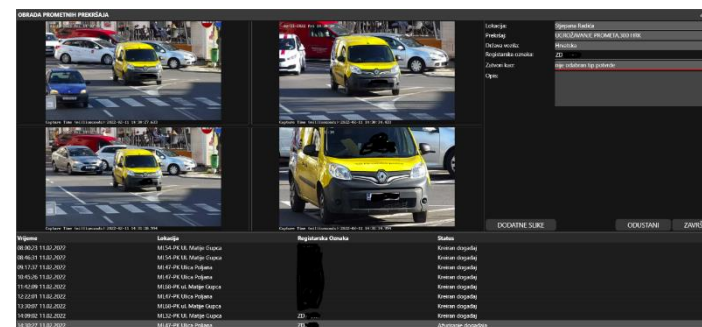
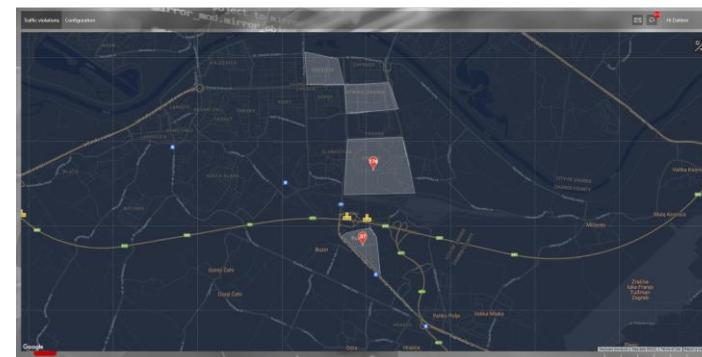

# Prometno redarstvo, uvođenje reda u promet u mirovanju



Traffic violations Reports Configuration Hi King

**PROCESSING OF TRAFFIC OFFENCES**

Location: Matije Gupca  
 Home number: 616A  
 Offence: PJEŠAČKI OTOK,300 HRK  
 Vehicle country: Francuska  
 Licence plate: 943682414  
 Request tow truck: With tow truck  
 Close as: All data collected  
 Description: Vehicle on sidewalk

ADDITIONAL PICTURES CANCEL FINISH

Time	Location	Licence plate	State	Generated
09:56:15 04.27.2022	ML54-PK Ul. Matije Gupca		Event created	Automatski
09:55:23 04.27.2022	ML47-PK Ulica Poljana		Event created	Automatski
09:53:33 04.27.2022	ML54-PK Ul. Matije Gupca		Event created	Automatski
09:51:55 04.27.2022	ML54-PK Ul. Matije Gupca		Updating event	Automatski
09:49:35 04.27.2022	ML32-PK Ul. Matije Gupca		Event created	Automatski
09:44:37 04.27.2022	ML54-PK Ul. Matije Gupca		Event created	Automatski
09:17:40 04.27.2022	ML32-PK Ul. Matije Gupca		Event created	Automatski
09:12:16 04.27.2022	ML32-PK Ul. Matije Gupca		Event created	Ručno
09:10:24 04.27.2022	ML47-PK Ulica Poljana		Event created	Automatski
09:05:19 04.27.2022	ML54-PK Ul. Matije Gupca		Event created	Automatski

# Prometno redarstvo, uvođenje reda u promet u mirovanju

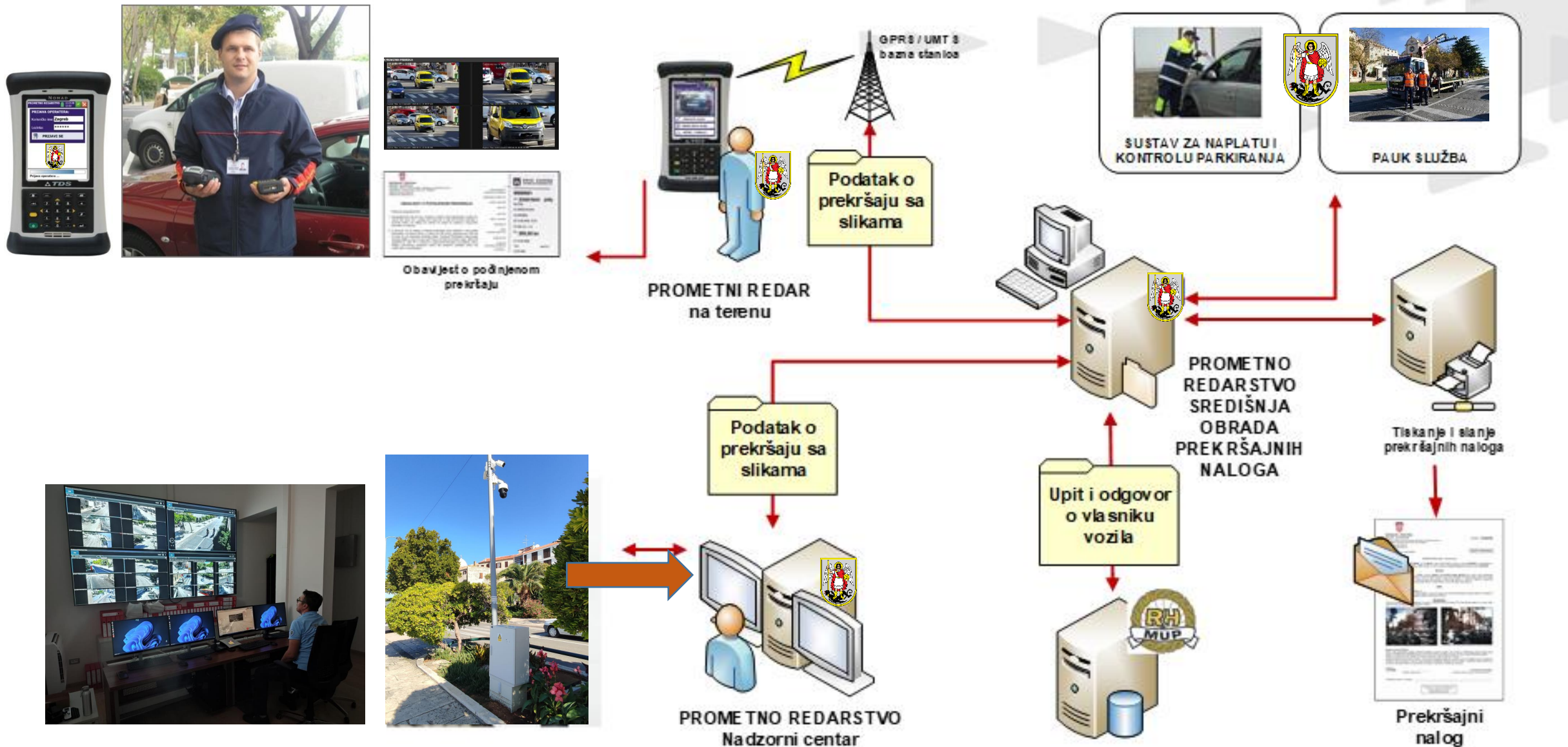



# Sustav video nadzora javnih površina



- Visoka razina nadzora i zaštite opreme na udaljenim lokacijama s integriranim sustavom besprekidnog napajanja



# Implementacija nadzornog centra

- Sustav tehničke zaštite nadzornog centra (videonadzor, kontrola pristupa, protuprovala),
- ICT infrastruktura (poslužitelji, sustav pohrane, mrežna oprema)
- Klijentska računala i monitori
- Centralni sustav nadzora i upravljanja

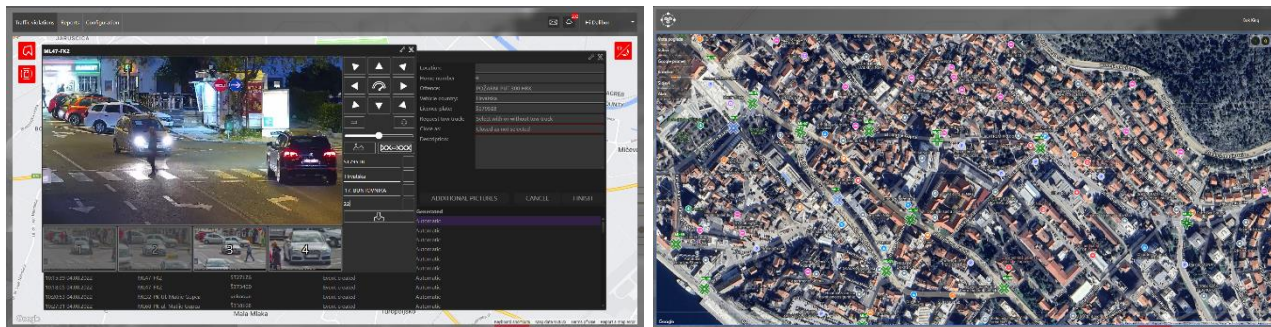



# Hvala na pozornosti!

Danijel Mileta, zamjenik gradonačelnika Grada Šibenika